

TORQUEEDO
STARNBERG.GERMANY

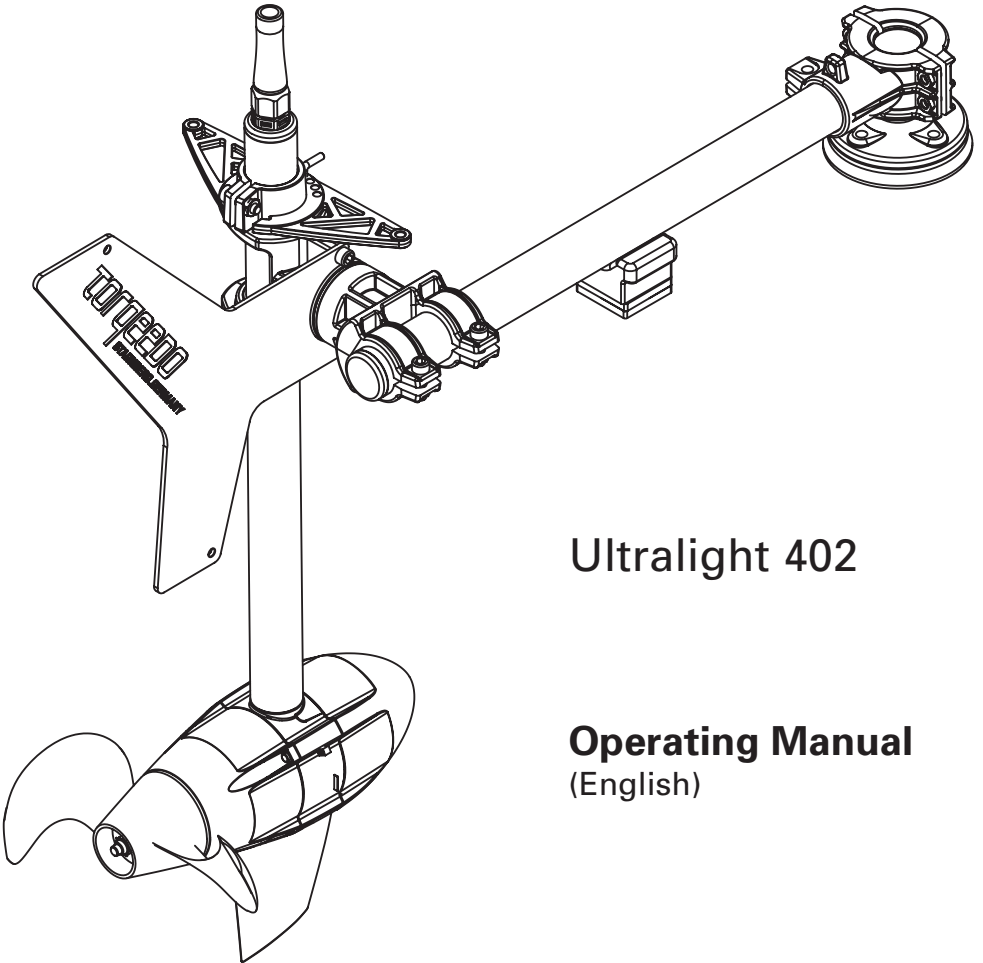

Ultralight 402

Operating Manual
(English)

1. Contents	
2. Important safety and operating instructions	4
3. Introduction	6
4. About this operating manual	7
5. Conformity declaration	7
6. Warranty conditions	8
6.1 Extent of warranty	8
6.2 Warranty process	9
7. Equipment and operating elements	10
7.1 Supply scope	10
7.2 Plan of operating elements	11
8. Starting up	12
8.1 Attaching and aligning the outboard motor to the kayak	12
8.2 Commissioning the tilting device	19
8.3 Attaching the steering	19
8.4 Connecting the remote throttle control with the integrated display and magnetic key	20
8.5 Connecting the battery pack	20
9. Operation	21
9.1 Battery pack and power supply unit	21
9.2 Tilting device and lock	22
9.3 Remote throttle with integrated display and magnetic key	23
9.4 Pylon	28
9.5 Ideal depth of immersion	29
10. Disassembly	29
11. Storage and care instructions	30
11.1 Corrosion protection	30
11.2 Caring for the battery	30
11.3 Changing the propeller	31
11.4 Other care instructions	31
12. Troubleshooting	32
13. Technical data	33
14. Disposal instructions	34
15. Accessories	34
16. Torqeedo Service Centers	36

2. Important safety and operating instructions

Important safety instructions



Torqueedo motors are designed to operate safely and reliably as long as they are used according to the operating manual. **Please read this manual carefully** before you start the motor. Ignoring the instructions in this operating manual can cause damage or personal injury. Torqueedo accepts no liability for any damage caused by actions that contradict this operating manual.

To ensure safe operation of the motor:

- Familiarize yourself with all the motor controls. For instance, you should be able to stop the motor quickly if necessary.
- Only allow adults who have been instructed on how to operate the motor or have read the operating instructions to run it.
- Never operate the motor if someone is in the water close to the boat. Stop the motor immediately if someone goes overboard.
- Always take a paddle with you on board.
- Check the status and function of the device before each tour.
- Note that the on-board computer does not include changes to currents and wind conditions in the range calculation. If you are moving with the wind or current the remaining range is calculated assuming you continue going with the wind or current. If you change direction or if wind/current change, your remaining range may be significantly lower. Therefore note the effect that the wind and current along your route have on your range.
- Never use the motor as a fixing point for your kayak; never use the motor as a handle for lifting or carrying.
- Do not open the battery casing; protect the battery pack from mechanical damage.
- Do not short circuit the battery pack.
- Avoid submerging the battery pack and remote throttle for longer periods of time.
- If the error code E46 is shown in the display or if you changed the fuse of the battery the information in the display is not accurate any more. After a complete charge of the battery, the information displayed is reliable again.
- The battery of your Ultralight motor has been declared a hazardous item in UN Class 9. Private transportation is not critical. If shipped by a transport company the relevant statutory provisions must be observed.
- Keep the magnetic key supplied at least 50 cm / 20 inches away from pacemakers.
- Keep the supplied magnetic key away from magnetic information media (e.g. debit/credit cards, music cassettes, magnetic tapes etc.). The magnet integrated in the key has enough strength to make the saved data unusable.

2. Important safety and operating instructions

Important operating instructions



There follows a selection of the most important instructions for handling Torqeedo Ultralight motors. Apart from these instructions, please observe the complete operating instructions to prevent damage to your motor.

- Only run the motor when the propeller is under water. If it is run in the air for longer periods, the shaft sealant rings that seal the motor to the drive shaft may become damaged. If the motor is run in air for a longer period, the motor itself can overheat.
- The Ultralight product range, the associated remote throttle, battery pack, and all electric, plug-in connections are protected against dirt and water in line with protection type IP68.
- The Ultralight has an integrated protective device that switches the motor off when it reaches a particular slope (90°). This prevents the propeller from turning if the boat capsizes or tilts.
- After use, always take the motor out of the water.
- After operation in salty or brackish water, wash all components in fresh water.
- Occasionally use contact spray to care for all electronic contacts. If you use the motor in salt or brackish water, we recommend applying contact spray once a month.
- You extend the life of your battery if you do not expose it for longer than necessary to a very hot environment. In order to guarantee that the life of the battery is as long as possible the battery should be stored for longer period of time (e.g. over the winter) at around 50 % charge and between 0 °C and +15 °C / +32 °F and +60 °F.
- Only charge the battery at environmental temperatures between 0 °C and +45 °C / +32 °F and +113 °F.
- Store the motor, battery pack, and remote throttle in the waterproof travel bag only when dry. If storing the items for longer periods of time in the travel bag, do not close it so it is airtight.
- Only use the travel bag for transportation not for shipping the motor. The motor stored in the travel bag must not be adversely affected by heavy objects.
- If the motor has malfunctions an error code is shown on the display. After resolving the error the motor can be restarted out of the stop position again. In rare cases it may be necessary to switch the motor off using the “on/off” button. You will find descriptions and details in Section 9.3.
- Do not disconnect the cable connections when the propeller is turning.
- If you have a problem with your motor, please follow the instructions in this operating manual for handling warranty claims.

3. Introduction

Dear customer,

We are delighted that you have chosen our motor. Your Torqeedo Ultralight is state-of-the-art in terms of motor, battery, and propeller technology. It has been designed and manufactured with the utmost care and with a special focus on comfort, user-friendliness, and safety, and has been extensively tested before delivery.

Please take the time to read this operating manual carefully so that you can use the motor properly and enjoy it for a long time.

We constantly strive to improve Torqeedo products. Should you have any comments on the design and use of our products, we would be pleased to hear from you. Please contact our Customer Services if you have any questions on Torqeedo products (service_usa@torqeedo.com or service_international@torqeedo.com).

We hope you will enjoy this product.

Yours,

Friedrich Böbel, PhD
Managing Director

Christoph Ballin, PhD
Managing Director

Matthias Janzen
Managing Director

4. About this operating manual

This operating manual will help you use your Torqeedo Ultralight safely and efficiently. All information is given according to our latest knowledge. Subject to technical changes.



- Indicates a danger or a procedure that may cause injury and property damage.



- Indicates a danger or a procedure that may cause property damage.

5. Conformity declaration

We, Torqeedo GmbH, with sole responsibility, declare the conformity of the Ultralight product range with the following provisions:

Small water vehicles
Electrical systems
Low-voltage direct current (DC) systems
DIN EN ISO 10133:2000

Starnberg, in March 2009



Managing Director's signature

The aforementioned company holds the following technical documents available for viewing:

- Required operating manual
- Plans/software source code (EU authorities only)
- Inspection records (EU authorities only)
- Other technical documentation (EU authorities only)

6. Warranty conditions

6.1 Extent of warranty

Torqueedo GmbH, Petersbrunner Straße 3a in D-82319 Starnberg, Germany, guarantees the final purchaser of a Torqueedo outboard motor that the product is free from material and manufacturing faults during the period stated below. Torqueedo will indemnify the final purchaser for any expense for the repair of a material or manufacturing fault. This indemnification obligation does not cover the incidental costs of a warranty claim or any other financial losses (e.g. costs for towing, telecommunications, food, accommodation, loss of earnings, loss of time etc.).

The warranty ends two years after the date on which the product was delivered to the final purchaser. Products that are used commercially or by public authorities - even if only temporarily - are excluded from this two-year warranty. In these cases, the statutory warranty applies. The right to claim under warranty runs out six months after discovery of a fault.

Torqueedo decides whether faulty parts are repaired or replaced. Distributors and dealers who repair Torqueedo motors have no authority to make legally binding statements on behalf of Torqueedo.

Normal wear and tear and routine servicing are excluded from the warranty.

Torqueedo is entitled to refuse a warranty claim if:

- the warranty was not correctly submitted (in particular failure to contact Torqueedo before sending back goods, failure to present a completely filled-in warranty certificate and proof of purchase, refer to Warranty process),
- the product has been used improperly,
- the safety, operating and care instructions in the manual were not observed,
- the product was in any way altered or modified or parts and accessories were added that are not expressly permitted or recommended by Torqueedo,
- previous services or repairs were not carried out by firms authorized by Torqueedo, or non-original parts were used.

As well as the rights arising from this warranty, the customer also has legal warranty claim rights arising from the purchase contract with the dealer that are not hampered by this warranty.

6.2 Warranty process

Adhering to the following warranty process is a prerequisite to the satisfaction of any warranty claims.

Before dispatching any apparently faulty goods, it is imperative to coordinate the delivery with Torqeedo Services. You can contact us by phone, email or mail. The ability to make contact via the www.torqeedo.com website is being extended successively. You can find the contact details on the back of this manual. **Please understand that we are unable to deal with products of which we have not been notified and will therefore refuse to accept delivery.**

To check a warranty claim and to process a warranty, we require a completed **warranty certificate** as well as **proof of purchase**.

- The warranty certificate attached to this operating manual must show contact details, product details, serial number, and a brief description of the problem.
- Proof of purchase must indicate the purchase and the date of purchase (e.g. transaction receipt).

For returning the motor to the Service Center, we recommend keeping the original Torqeedo packaging. If this is no longer available packaging that excludes transport damage must be used as this is not included in the warranty.

We are available to answer any questions regarding the warranty process - simply use the details on the back cover.

7. Equipment and operating elements

7.1 Supply scope

The full supply scope of your Torqeedo Ultralight should include the following parts:

- Motor unit with shaft and connection cable (2 m / 6.5 feet), universal joint with swing arm, pylon, and propeller
- Boom with clamping device and mounting ball
- Lithium-manganese battery with integrated GPS receiver
- Remote throttle control with integrated display
- Magnetic key
- Assembly set with fixing material, rubber rest, line, elastic cord, lock bolt and accessories
- Allen key SW5
- Battery pack connection cable – remote throttle (1.5 m / 5 feet)
- Travel bag
- Power unit incl. European power cord, US power cord and UK adapter
- Operating manual
- Warranty certificate
- Packaging

7. Equipment and operating elements

7.2 Plan of operating elements

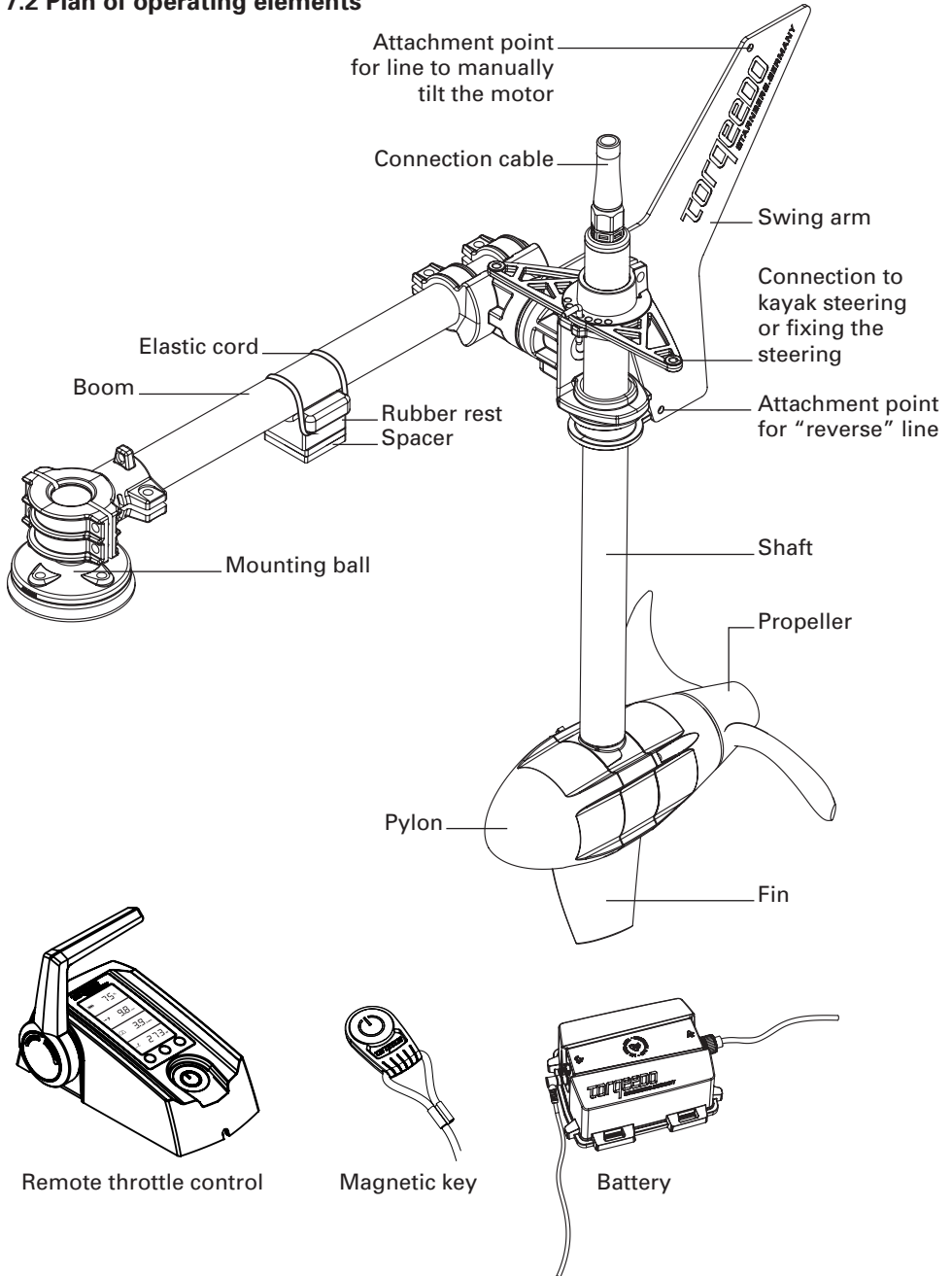

8. Starting up

8.1 Attaching and aligning the outboard motor to the kayak

1. Prepare the motor for the mounting:

Remove the parts that belong to the Ultralight supply scope from the packaging. Slide the boom with the clamp into the universal joint and clamp it lightly with the two screws.

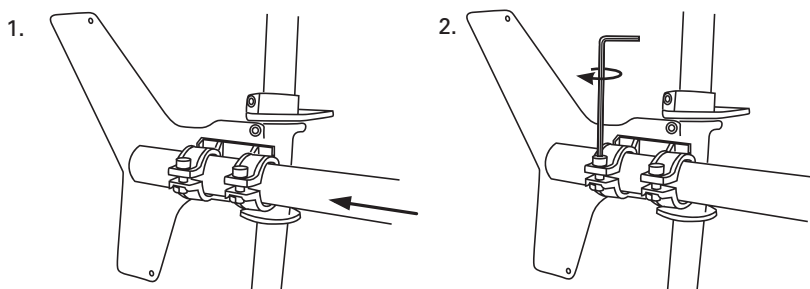

2. Select the position where the drive is to be attached to the kayak.

For this please note:

- You need a virtually flat surface on the kayak that is big enough to attach the mounting ball.
- The motor's boom must be horizontal, i.e. run parallel to the surface of the water. This ensures that the shaft pipe is vertical in the water when moving forward.

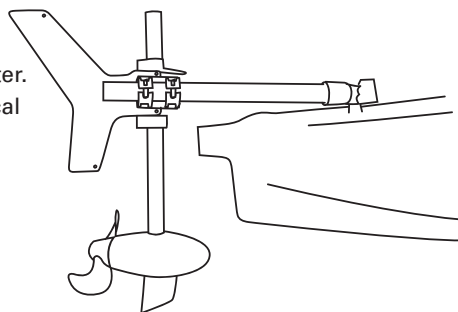

- To attach the motor to thin-walled touring kayaks it is necessary to use the rubber rest so that the engine rests on two points on the kayak (mounting ball and rubber rest). On thicker-walled angling and leisure kayaks it may be possible to fix the motor only with the aid of the mounting ball without a second resting point.

There are three options for connecting the drive to your kayak:

A No connection of the motor to the kayak's steering system: When travelling with the motor you must either steer using the paddle or with a rudder that is not connected to the motor. With this option it is not possible to move in tight circles using the motor. This type of attachment is recommended if your kayak does not have a steering system or if you only need the motor for support or as a back-up on long tours (and do not have to move in tight circles).

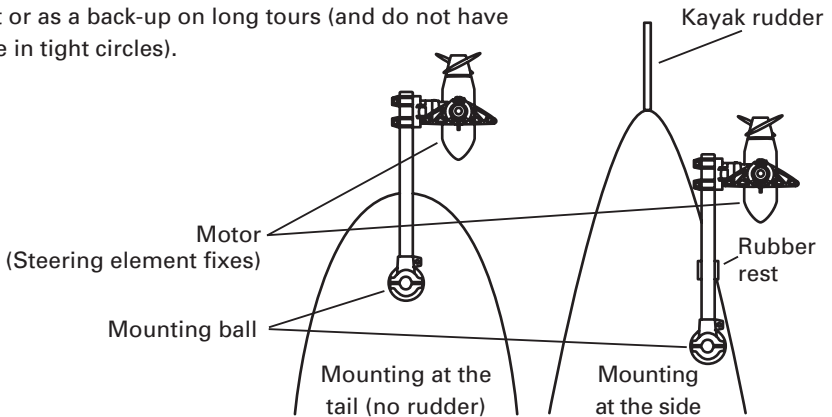

B Connecting the motor instead of the rudder to the kayak's steering system: With this attachment option you can move your kayak very easily using the motor; but the rudder is not available when the motor is not in use.

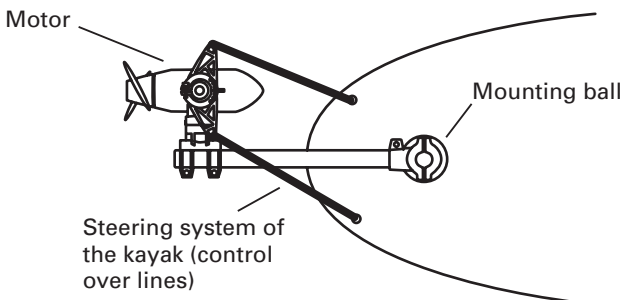

- Test whether the steering operates in the desired position before fixing the mounting ball to the kayak.

C Fixing the motor to the kayak's steering system in addition to a rudder:

We recommend this attachment option if you want to use a rudder when the motor is running but also when paddling (while the motor is tilted out of the water).

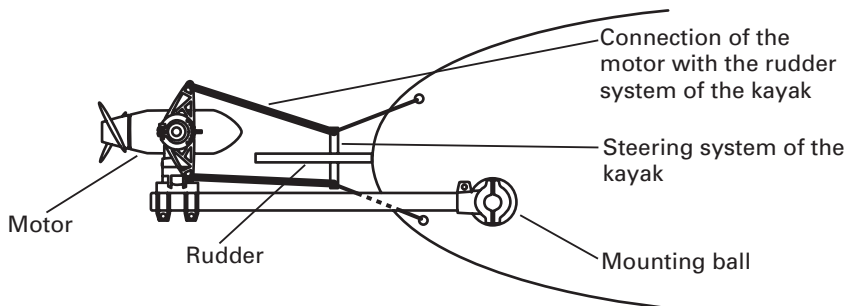

- Test whether the steering works in the desired position and whether the kayak's motor and rudder can be tilted out of the water before fixing the mounting ball to the kayak.
- The holes for the screw anchors need to have a distance of 2 cm / 0.8 inches to any edge of the kayak.

Mark the four necessary screw positions on the mounting ball and drill the corresponding holes (Ø 12 mm / 0.47 inches) into the kayak.

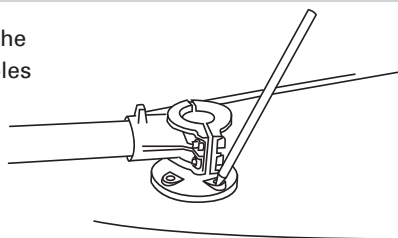

3. Attach the mounting ball to the Kayak.

You have 2 options to attach the mounting ball to the kayak. If the inside of the kayak hull is accessible we recommend to secure the mounting ball with the screws and nuts provided in the scope of delivery. If the inside of the kayak hull is not accessible, the mounting ball can be mounted with the screw anchors provided in the scope of delivery.

A Mounting with screws and nuts:

(recommended if kayak inside is accessible)

Drill four holes in the marked positions
Ø 6.5 mm (15/32 inch).

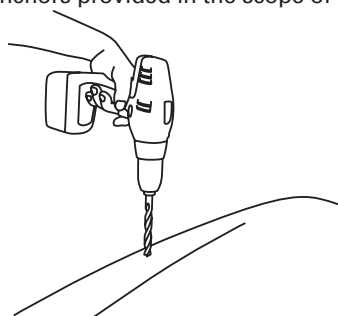

Attach the mounting ball with the screws and nuts provided in the scope of delivery. To close the boreholes watertight and to compensate for slight curvature of the kayak surface, use the rubber gasket between the kayak and the mounting ball. To reinforce the kayak hull under the mounting ball, place the white plastic plate with 8 holes from the inside between the kayak hull and the nuts.

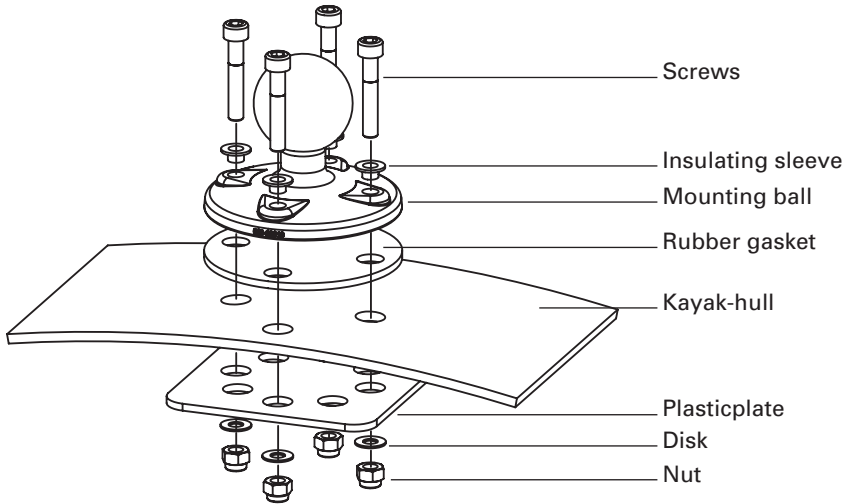

B Mounting with screw anchors:

(recommended if kayak inside is not accessible)

Drill four holes in the marked positions
 \varnothing 12 mm ($15/32$ inch).

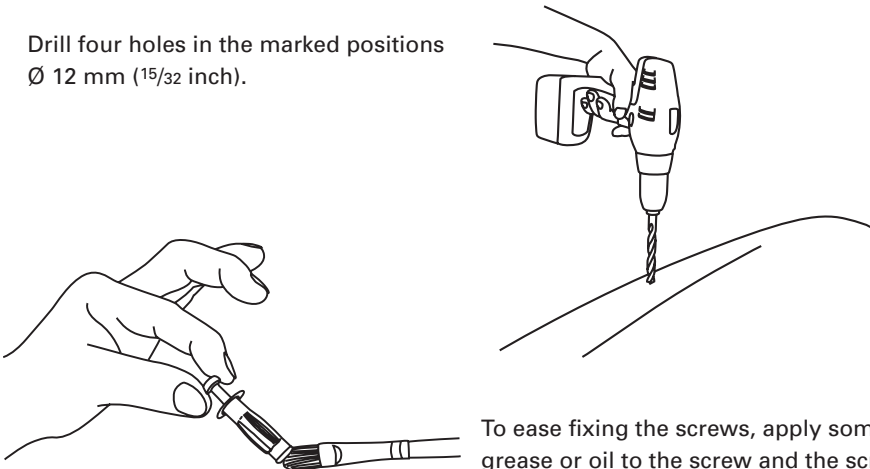

To ease fixing the screws, apply some grease or oil to the screw and the screw anchor.

Take the screws out of the screw anchors.
Place the aluminum key onto one of the screw anchors. The aluminum key prevents the screw anchor from turning when the screw is screwed in.



Place the screw anchor in one of the boreholes. Please note that the screw anchor needs to fit easily through the borehole without being compressed at the sides.

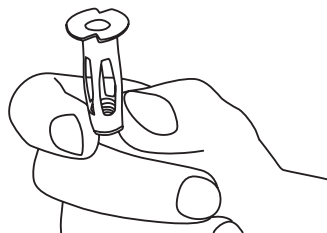

If possible, place the white plastic plate with 8 holes from the inside of the kayak over the screw anchor. This reinforces the kayak hull at the mounting point.

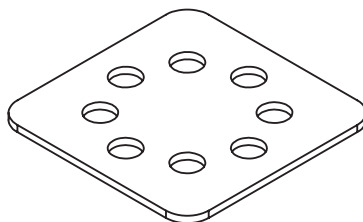

If this is not possible, the screw anchors can be fixed without the plastic plate.

Put a screw through the aluminum key into the screw anchor. Firmly tighten the screw while fixing the screw anchor with the aluminum key.

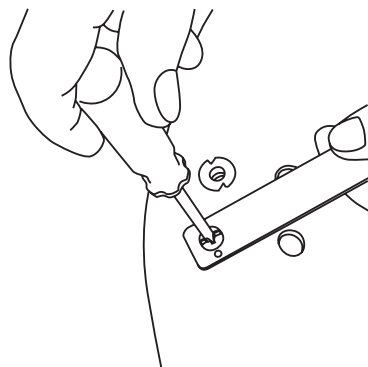

Kayak inside

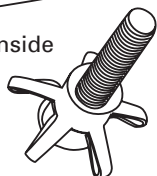

Note that the screw anchor will expand on the inside of the kayak. Chose a position for the wall anchor which allows sufficient space for this expansion.

Unscrew the screw and take the aluminum key off the screw anchor.

Fix the other screw anchors to the kayak in the same way.

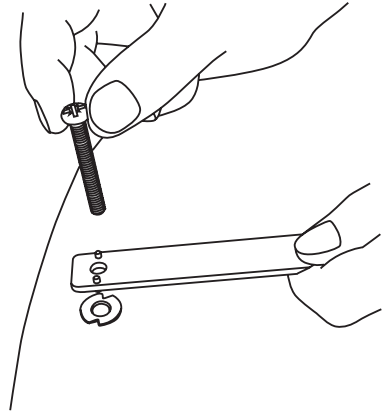

Place the rubber gasket over the four screw anchors.

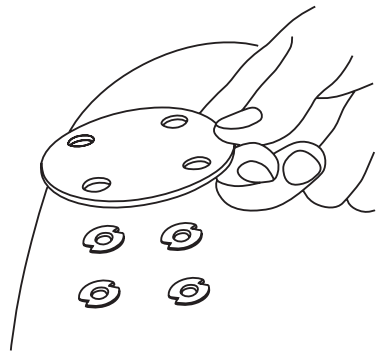

Place the mounting ball onto the rubber gasket. Insert the plastic insulating sleeves into the holes of the mounting ball. Insert the four screws through the insulating sleeves and tighten them firmly into the screw anchors.

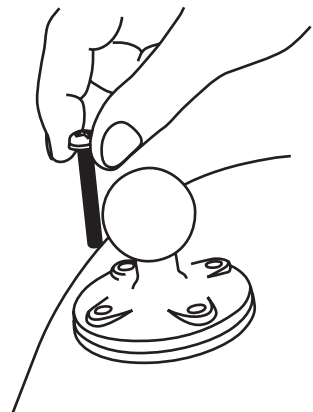

4. Assemble the drive by clamping the ball receiver to the mounting ball. For this the boom must be aligned horizontally to the water line. When tightening the screws in the ball clamp, ensure that the gap on both sides of the clamp is the same distance.

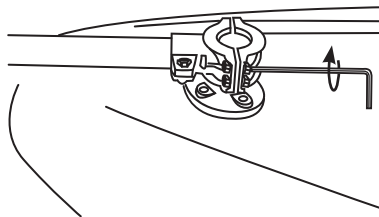

5. If desired, mount the rubber rest on the second motor resting point. Select the desired location and use the spacers supplied to balance out the height. Attach the rubber rest in the same fashion used to attach the ball mount by using two screw anchors. Fix boom to the rubber rest using the elastic cord.

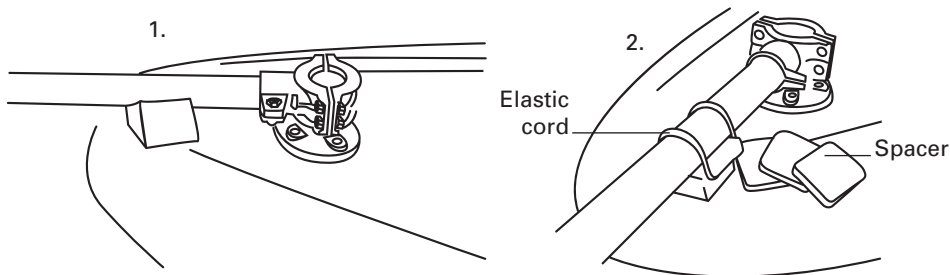

6. Loosen the screws on the two clamping rings and position the motor so low that the propeller does not draw air even at full throttle. Then retighten the two screws. Ensure that the upper clamp ring is perpendicular to the propeller axis.

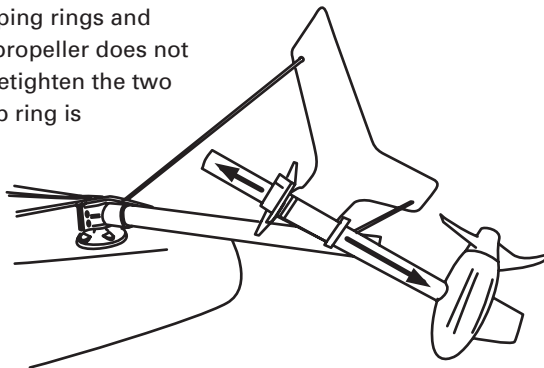



- If you are unsure about the position and assembly of your motor contact your Torqeedo dealer.
- Ensure that when tilting the motor the cables are not crimped.

8.2 Commissioning the tilting device

1. Mount a clamp block at the level of the driver's seat. Position the clamp block so that it will hold a line if it is pulled towards the stem of the kayak.
2. Cut the supplied line to 2 x 3 m (10') and 2 x 0.5 m (2.5'). Melt the ends e.g. with a lighter.
3. Firmly tie one of the 3 m (10') lines to the top of the swing arm. Guide the line through the loop on the ball clamp and fix it in the clamp block. In this way you have the opportunity to tilt the motor out of the water and to hold it in the tilted position.

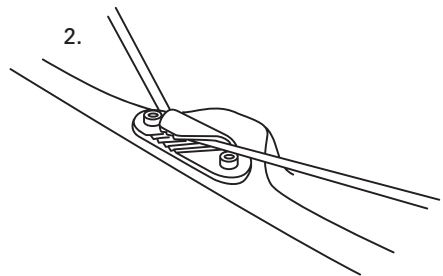
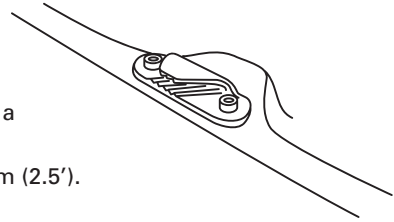
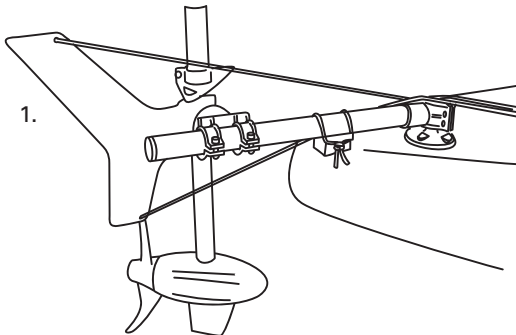

4. If you want to use the motor in reverse, mount the second clamp block and guide the line to the lower end of the pivot arm. This protects the motor from undesired tilting up.

8.3 Attaching the steering

The following steps are only relevant if you want to connect the motor to the kayak's steering system.

1. If you want to connect the motor with the kayak's steering system **instead of the rudder**: Fix the lines from the kayak's steering with the triangular clamp ring at the upper end of the motor shaft. Extend the lines for the kayak's steering as far as necessary, if appropriate you can use the supplied snap hooks to fix the lines to the clamp ring.

2. If you want to connect the motor to **the kayak's rudder (and via the rudder to the steering system)**: Fix the two snap hooks supplied to the short lines. Now connect the kayak's rudder with the triangular clamp ring at the upper end of the motor shaft using the short lines. To do so insert the snap hooks into the holes in the clamp ring and tie the other end of the line to the kayak's rudder. Movements of the rudder to the left or right should produce the corresponding steering movements of the motor. For good steering it is not essential for the steering movements to be identical.

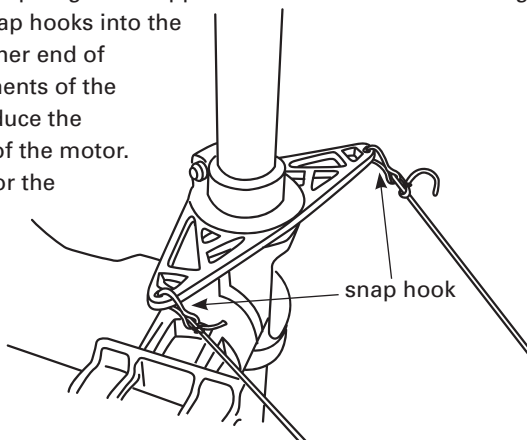

8.4 Connecting the remote throttle control with the integrated display and magnetic key

Position the remote throttle in the desired position and fix it, e.g. with a RAM mount holder (M4 thread in the base of the remote throttle control) or a commercial Velcro strip (not within the scope of supply).

8.5 Connecting the battery pack

1. Insert the battery pack in the desired position in the kayak and fix it if necessary with straps (not within the scope of supply). When doing so ensure that the top of the battery (aerial icon) is showing upwards in order to provide the GPS function. Do not cover the battery pack with metallic objects or those containing metal (e.g. rescue blankets etc.).
2. Connect the cable from the motor to the battery pack. Ensure that there is a waterproof bayonet closure that is placed in a particular position and screwed into place.
3. Connect the cable from the remote throttle to the battery pack. Ensure that the connection is waterproof and screwed into place. It can only be fixed in one position.

9. Operation

9.1 Battery pack and power supply unit

The battery pack is equipped with high performance lithium manganese batteries, so-called LIMA cells. The LIMA cells have a self-discharge of under 1 % per month at 20 °C / 70 °F, have stable cycles, and no memory effect. The lithium battery can be used at environmental temperatures from -20 °C to +60 °C / -4 °F to +140 °F.

A controller that has several functions to protect and care for your battery is integrated in the battery pack. The controller, amongst other functions, protects the battery from fully discharging and overcharging. Therefore you can connect the battery to the charger without worrying or empty it completely.

During the charging process the controller contained in the battery pack controls the charging current.

The capacity of the battery pack changes over time. To adjust the capacity indicator we recommend emptying the fully charged battery completely once a year at average speed.

The battery pack has a 20 A safety fuse. Open the marked cover in the battery's base to exchange the fuse. When closing the cover ensure the cover and seal sit properly (label to the outside).

The charging unit supplied is modified to the controller and charges the Ultralight's battery pack in approximate 8 hours. When charging at high environmental temperatures (> 35 °C / > 95 °F) longer charging times may occur as the controller is equipped with a temperature-dependent charging power off switch which ensures a proper and gentle charging of the cells. For charging, connect the charging unit with the battery pack and the power supply. To do so remove the motor cable on the battery pack and use the same jack for charging.

You can charge the battery pack without the remote throttle being inserted. If the remote throttle is connected with the battery pack the current charging status in percent and „charging“ is displayed in the topmost field on the display.



- The battery is protected from water penetration (IP68).
- Use the Ultralight battery 402 exclusively with the Ultralight 402 outboard motor.
- Only use the power supply unit supplied or one authorized by Torqeedo to charge the battery pack.
- Only charge the battery at environmental temperatures between 0 °C and 45 °C / +32 °F and +115 °F.
- You extend the lifespan of your battery if you do not expose it to hot environments for longer than necessary. In order to guarantee the longest possible lifespan of the battery if you store it for a long time (e.g. over the winter) it should be charged to around 50 % and stored between 0 °C and +15 °C / 32 °F and +60 °F.



- Protect the battery pack from mechanical damage. If the housing of the battery is damaged, do not use the battery.
- Do not short circuit the battery pack.
- Avoid submerging the battery pack for longer periods of time.
- The LIMA battery cells only catch fire if they are exposed to temperatures over 300 °C / 570 °F. This is an important advantage over other lithium-based battery systems. If this should occur try to put the battery in a location where it will not cause damage. If this is not possible, keep your distance or cover the battery with sand or other dry, non-flammable materials.

9.2 Tilting device and lock

For normal movement the fixing lines that go to the lower end of the swing arm should not be fixed in the clamp block. This enables the motor to tilt up if it gets in contact with obstacles under water. To move in reverse the lower fixed line must be fixed to the clamp block.

To tilt the motor the lower fixing line **must** be released. By pulling the upper line the motor can be tilted out of the water and fixed in that position using the second clamp block. The motor does not start if it is tilted up.

Loosen the upper line to lower the motor.

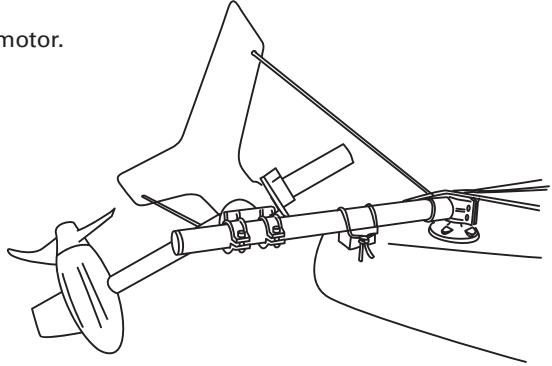

To lock the steering of the motor insert the lock bolt into the desired position in the upper clamp ring. This blocks the steering function.

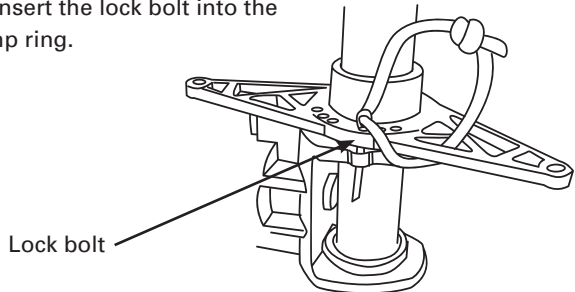

- Only tilt the shaft when the lower fixing line is loose.
- For steering the lock bolt must be removed from the upper clamp ring.

9.3 Remote throttle with integrated display and magnetic key

Control the drive power – speed and rotation direction - by adjusting the remote throttle. Forward movement of the remote throttle means the kayak moves forward, backward movement of the remote throttle means the kayak moves backwards. Please note that **reverse movement does not have the same output as forward movement**. The middle position corresponds to the stop position.

The remote throttle is equipped with a **magnetic key** with an on/off function. The motor only works if you place the magnetic key supplied on the proper location on the remote throttle control (see drawing). If the magnetic key is removed the motor stops. You can

only start the motor again if you first replace the magnetic key and then move the remote throttle to the central position (stop position).

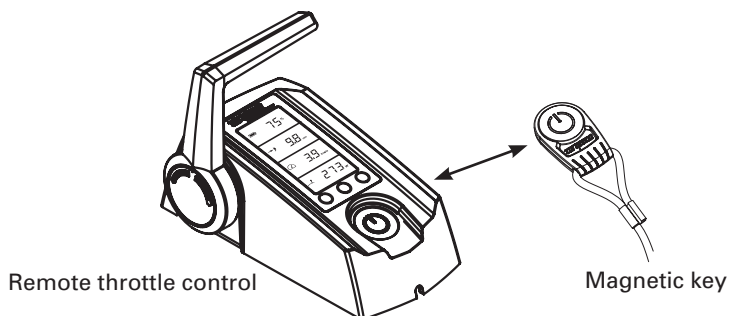

The remote throttle is equipped with an **on-board computer with an integrated display** and three buttons.





If you press the “on/off” button for 1 second you switch the motor on. Pressing the button again for 3 seconds switches the motor off again. You can switch the motor off in any operating mode. If there is no activity for one hour the motor switches off automatically. Press the button again to switch it back on.







Use the “setup” button to set the units for the display. You enter the menu by pressing the “setup” button for 3 seconds. First you can select the units in which the remaining range is displayed. By pushing the button in the center of the display you select between kilometers, miles, nautical miles, and hours. You confirm your selection by pressing “setup” again. You then enter the speed indicator setting. You can choose between kilometers per hour, miles per hour, and knots. Again you select the units with the center button and confirm your selection and leave the “setup” menu again by pressing the “setup” button again.

The “cal” label on the center button stands for “calibration”. If the display shows a relevant error message you can recalibrate the motor with the help of this button. You will find details on this in the „error codes” table in this section.

Display in normal operation:

 85%	Battery charge status in percent
 113 miles	Remaining range at current speed
 4.5 mph	Ground speed
 273 W	Power consumption in Watt

Other indicators:

Drive slowly  88.8% Charging
 8:88 Searching
 88.8 mph Searching
 88.88 Ah ERROR

Drive slowly: Is displayed when the battery capacity is < 20 %.

Charging: Is displayed when charging. Refer to Section 9.1.

: The GPS module integrated into the battery pack searches for satellite signals to determine the position and speed. If no GPS signal is received within 5 minutes the display switches in the second field from “remaining range at current speed” to “remaining time at current speed”. In addition, a clock icon is displayed. If the remaining duration is more than 10 hours it is indicated in whole hours. If it is less it is shown in hours and minutes.

: This icon is displayed if the remote throttle must be placed in the central position (stop position). This is necessary before starting off.

: Is displayed if the temperature of the engine or battery is too high. The motor decreases the input power automatically.

Error: If an error occurs the error icon and a two-digit code are displayed in the bottom field. The code shows the component causing the error and the error itself. You will find details about the error codes in the following table.



- For reverse movement the fixing line that goes to the lower end of the swing arm should be fixed in the clamp block.
- The remaining distance or time at the current speed shown on the display is a calculated theoretical value. Please be aware that the actual outstanding range or duration may vary.



- The high thrust of the drive makes it necessary to familiarize yourself with the characteristics of your Torqueedo Ultralight 402. Practice handling the motor and maneuvering in open water.
- We recommend fixing the magnetic key lanyard to a personal flotation device (PFD).
- Keep the magnetic key supplied more than 50 cm / 20 inches away from pacemakers as strong magnets could affect the operation of the pacemaker.
- Keep the supplied magnetic key away from magnetic information media (e.g. debit/credit cards, music cassettes, magnetic tapes etc.). The magnet integrated in the key has enough strength to make the saved data unusable.
- If the remote throttle's casing is damaged there is a risk of water infiltration which could cause the propeller to turn uncontrollably. For this reason the remote throttle must be exchanged immediately.

The following table contains a list of possible error codes. After resolving the error the motor can be moved out of the stop position again. In rare cases it may be necessary to switch the motor off using the "on/off" button on the remote throttle control.

Fault codes		
Display	Cause	What to do
E02	Stator over-temperature (engine overheating)	Motor can be used again after a short wait (about 10 minutes). Contact Torqeedo Service.
E03	Motor tilted during operation	Motor can be used again after tilting it down and pressing on/off.
E04	Motor put into operation while tilted	Motor can be restarted from the stop position after being tilted down.
E05	Motor/propeller blocked	Loosen blockage and turn propeller one revolution by hand.
E06	Voltage in the motor too low	Low battery charging status. Motor can be used again slowly from the stop position.
E07	Motor overcurrent	Continue at low output. Contact Torqeedo Service.
E08	Circuit board overheating	Motor can be used again after a short wait (about 10 minutes). Contact Torqeedo Service.
E21	Remote throttle calibration defective	<ul style="list-style-type: none"> • Re-calibrate: Press "cal" button for 10 seconds. • The display shows "cal up": Press remote throttle control forward to full gas then press the "cal" button. • The display shows "cal stp": Return remote throttle control to central position then press the "cal" button. • The display shows "cal dn": Press remote throttle control reverse to full gas then press the "cal" button.
E22	Magnetic sensor defective	Re-calibrate (refer to E21).
E23	Value range false	Re-calibrate (refer to E21).
E30	Motor communication error	Check the motor cable's plug-in connection. Check the motor cable for damage. Check the fuse at the underside of the battery. It applicable replace fuse. If the fuse was replaced the information display will not show correct data until the battery is fully charged again.

Fault codes		
Display	Cause	What to do
E32	Remote throttle control communication error	Check the remote throttle control cable's plug-in connection. Check the cable.
E33	General communication error	Check the plug-in connections and cables. Switch the motor off and on again.
E41, E42	Incorrect charging voltage	Check whether the power supply unit used has an output voltage between 10 V and 20 V. If necessary contact Torqeedo Service.
E43	Battery empty	Charge battery. Motor can be used again slowly from the stop position if necessary.
E45	Battery overcurrent	Switch motor off and on again. The information display will not show correct data after this error occurred. The battery needs to be fully charged to reset the information system.
E46	Battery operating temperature error	Battery cells outside operating temperature between -20 °C and +65 °C / -4 °F and +150 °F. The motor can be used again when the temperature has stabilized.
E48	Charging temperature error	Charging will continue when the cell temperature is between 0 °C and +45 °C / +32 °F and +115 °F.
Other error codes	Defects	Contact Torqeedo Service and notify them of the error code.

9.4 Pylon

The **motor** and the **electronic control system** are located in the pylon and generate the propulsion. In addition, several protective functions are integrated:

1. **Temperature protection:** If the motor overheats, the motor control system reduces the output of the drive until a temperature equilibrium is established between generated and disposed heat. Above a critical temperature the motor stops and the display shows error code E02 or E08.
2. **Blocking protection:** If the propeller is blocked or stuck, the motor would normally consume too much power. In this case, the motor is switched off within a few hundredths of a second to protect the electronics, motor winding, and propeller. After removing the blockage you can switch the motor on again. If there is a blockage the display shows error code E05.

3. **Cable break protection:** If the connection cable is damaged, i.e. if the connection to the remote throttle, battery or motor is broken the motor will not start or stops. An error code starting with E3 and containing another number is shown on the display.
4. **Throttle control:** The propeller rev change responds slowly to protect mechanical drive components and avoid short-term power peaks.
5. **Location sensor:** The Ultralight has an integrated protective device that switches the motor off when it is beyond a particular slope (90°). This prevents the propeller from turning if the boat capsizes or tilts further.



- If the motor has a defect an error code is shown on the display. After resolving the error the motor can be moved out of the stop position again. You will find descriptions and details in Section 9.3.

The **Fin** supports steering movements and protects the propeller from hitting obstacles under water.



- Only run the motor when the propeller is under water. If it is run in the air, the shaft sealant rings that seal the motor to the drive shaft may become damaged. If the motor is run in the air for a longer period, the motor itself can overheat.
- After use, always take the motor out of the water. The tilting mechanism can be used for this.

9.5 Ideal depth of immersion

The depth of immersion of the propeller in the water affects the efficiency of your drive. You can optimize the propeller's depth of immersion with the help of the information on speed and consumption shown on the display.

10. Disassembly

1. Move the remote throttle control into the stop position and remove the magnetic key from the remote throttle. Then press the on/off switch to turn off the motor.
2. Remove all electrical connections between the remote throttle, battery pack, and motor.
3. Remove all lines for steering and locking.
4. Remove the four screws on the ball clamp and remove the drive.



- The pylon may be hot.



- Ensure that the motor's individual parts are dry before stowing it in the travel bag.
- Ensure you do not bend the cable and tackle line around sharp edges.
- Only use the travel bag for transportation not for shipping the motor. The motor stored in the travel bag may not be affected by heavy objects.

11. Storage and care instructions

11.1 Corrosion protection

Materials were chosen with a high level of corrosion-resistance. All of the materials used in the Ultralight 402 are, as with most leisure maritime products, classed as "seawater resistant", not "seawater-proof".



- After use you should always remove the motor from the water. The tilting mechanism can be used for this.
- After operation in salty or brackish water, wash all components in fresh water.
- Store the motor, battery pack, and remote throttle in the waterproof travel bag only when dry. If storing the items for longer periods of time in the travel bag, do not close it so it is airtight.
- **Treat all electronic parts with contact spray once a month**
- Check the cable regularly for damage.

11.2 Caring for the battery

You extend the lifespan of your battery if you do not expose it to hot environments for longer than necessary. In order to guarantee the longest possible lifespan of the battery if you store it for a long time (e.g. over the winter) it should be charged to around 50 % and stored between 0 °C and +15 °C / 32 °F and +60 °F.

11.3 Changing the propeller

1. Loosen the cable between the motor and battery.
2. Loosen and unscrew the central nut on the propeller.
3. Pull the propeller from the motor shaft.
4. Pull cylinder pin from the motor shaft and remove the disk spring from the motor shaft.
5. Connect the cable between the motor and battery. Allow the motor to run slowly and check whether the shaft is turning unevenly at the shaft sealing ring. Contact Torqeedo Service if the shaft is damaged or uneven.
6. Loosen the cable between the motor and battery. Place a disk spring onto the motor shaft. Note the direction of the disk spring: The inside rim of the disk spring needs to be in contact with the motor housing. Insert the new cylinder pin centrally to the motor shaft.
7. Place the propeller onto the motor shaft and turn the propeller so that the cylinder pin is aligned with the groove in the propeller.
8. Place a disk spring onto the motor shaft behind the propeller. Note the direction of the disk spring: The outside rim of the disk spring needs to be in contact with the propeller.
9. Tighten the central nut on the propeller by hand.

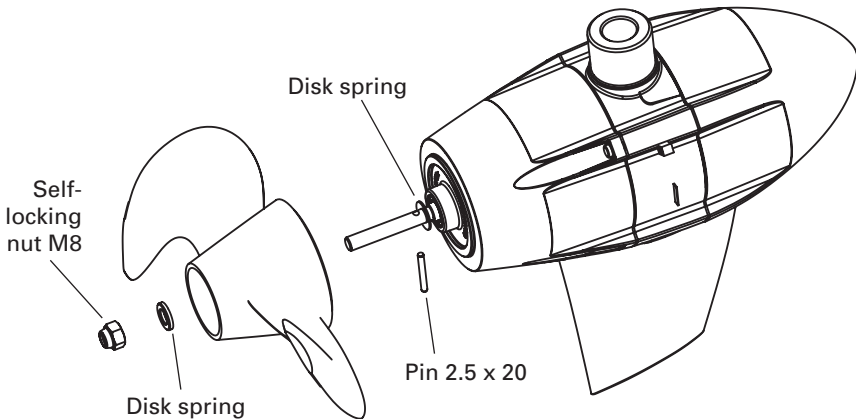

11.4 Other care instructions

Ensure that the storage points on the universal joint and shaft pipe are clean.

To clean the motor you can use any cleaning agents suitable for plastic - follow the manufacturer's instructions. Cockpit sprays available for cars achieve good results on the plastic surfaces of the Torqeedo Ultralight.

12. Trouble shooting

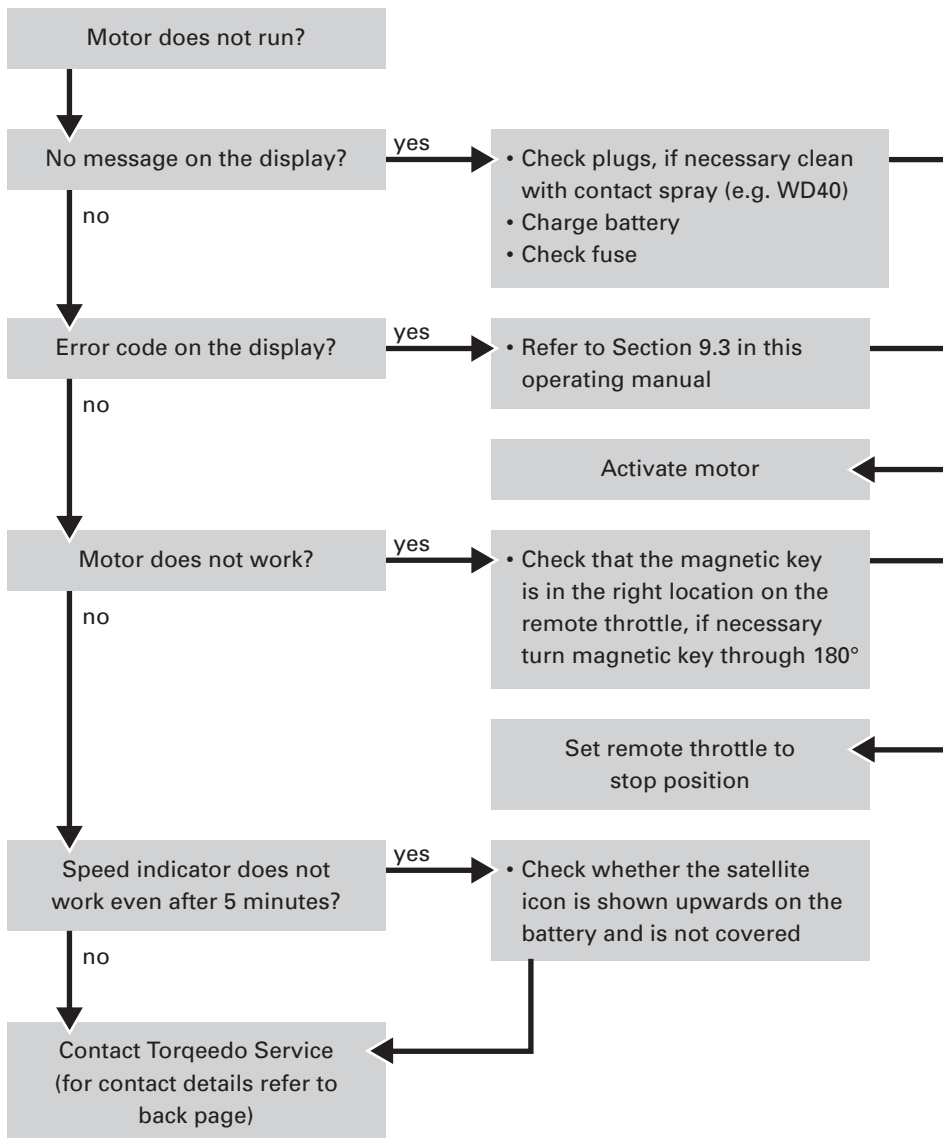



- Repairs may only be carried out by authorized Torqeedo Service Centers. If you attempt to make repairs yourself the warranty terminates immediately.
- In case of a warranty claim, please follow the warranty instructions at the beginning of the operating manual.

13. Technical data

	Ultralight 402
Input power in watts	400
Rated voltage in volts	28.8
Final voltage in volts	33.2
Propulsive power in Watts*	180
Comparable gas outboard motor (propulsive power)	1 HP
Comparable gas outboard motor (thrust)	2 HP
Maximal overall efficiency in %	45
Static thrust in lbs	33.0
Battery capacity in Wh	230 LIMA
Total weight in kg / lbs	7.0 / 15.4
Weight of motor without battery in kg / lbs	4.5 / 9.9
Weight of integrated battery in kg / lbs	2.5 / 5.5
Shaft length in cm / inches	45 / 17.7
Propeller dimensions in inches	8 x 8
Propeller speed at full power rpm	1,200
Control	Remote throttle control
Steering	Provision for connection to kayak rudder; lockable
Tilting device	Manual with grounding protection
Stepless forward/reverse drive	Yes using remote throttle control (reverse 50 % power)

* The effective output available to drive the boat (measured after deducting all losses incl. losses in the propeller). Definition of forward movement = thrust x speed.

14. Disposal instructions

Torqueedo Ultralight motors are manufactured in accordance with EU Directive 2002/96. This directive regulates the disposal of electrical and electronic devices to protect the environment.

You can, in line with local regulations, hand in the motor at a collecting point. From there it will be professionally disposed.



15. Accessories

Item no.	Product	Description
1411-00	Spare battery Ultralight 402	LIMA-high-performance battery with integrated GPS receiver, 230 Wh, 28.8 V, 8 Ah
1412-00	Charger for spare battery Ultralight 402	54 watt charger (12 V, 4.5 A) for chargingng Ultralight 402 batteries, for power connection with 100-240 V and 50-60 Hz
1912-00	Spare propeller Ultralight models	8" x 8" variable-pitch-variable-camber (VPVC) propeller, developed especially for kayaks and other ultra-light boats. Made of impact-resistant glass-fibre reinforced PBT (polybutylene terephthalate), complete with nuts, disc springs and shear pin

Torqueedo Service Centers

Europe and international

Torqueedo GmbH
Petersbrunner Str. 3a
82319 Starnberg
Germany

service_international@torqueedo.com
T +49 - 8151 - 268 67 -26
F +49 - 8151 - 268 67 -29

North America

Torqueedo Inc.
171 Erick Street, Unit A-1
Crystal Lake, IL 60014
USA

service_usa@torqueedo.com
T +1 – 815 – 444 88 06
F +1 – 847 – 444 88 07